

INA PHUSE50-N参数

| | | | | |
|--------|--------------------|------------------------------|----|-------------------------------|
| 尺寸 | J | 180 | mm | - |
| | J ₁ | 100 | mm | - |
| | K | 14 | mm | - |
| | K ₁ | M16 | | - |
| | L | 256 | mm | - |
| | L ₁ | 60 | mm | - |
| | Q | Rp 1/8 | | - |
| | S | 4 | mm | - |
| | S ₁ | 32.7 | mm | - |
| | V | 120 | mm | - |
| 重量 | m | 5250 | g | 质量 |
| 承载力 | C _{0r G} | 23200 | N | 轴承座的径向承载能力 |
| 基本额定载荷 | C _r | 35000 | N | 基本额定动载荷，径向 |
| | C _{0r} | 23200 | N | 基本额定静载荷，径向 |
| 说明 | | GG. HUE10-N / GEH. HUSE10 | | 轴承座的型号 |
| | | GRAE50-NPP-B | | 轴承的型号 |
| | | KASK10 | | 轴承端盖，封闭设计。 单独定货。 轴承端盖的槽 |
| 尺寸 | d | 50 | mm | - |
| | H | 130 | mm | - |
| | A | 36 | mm | - |
| | A ₂ | 30 | mm | - |
| | B ₁ | 43.8 | mm | - |
| | d _{3 max} | 69 | mm | - |
| | F | 20 | mm | - |
| | G | 80 | mm | - |
| | H ₁ | 60 | mm | - |

INA PHUSE50-N图片

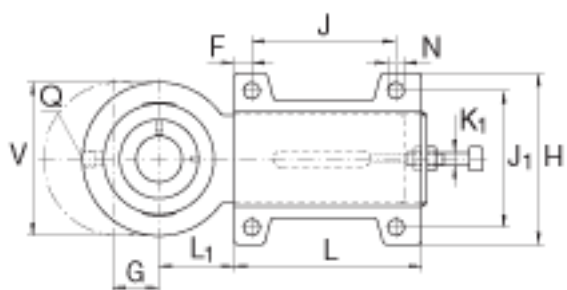
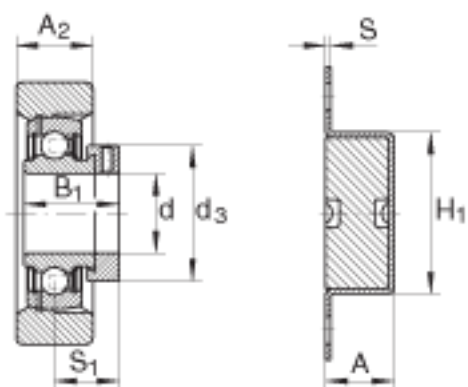
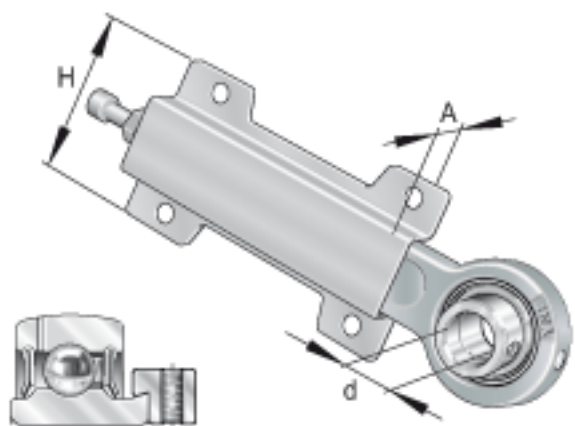

参考资料:<http://www.sozhou.com/p/ea82dc33.html>